



DMI 45 PORTABLE ASPHALT DRUM MIX PLANT

Fully towable single chassis with dual fuel burner, efficient drum design for an homogeneous mix, ships easily in only two 40' HC ocean containers and requires minimum reassembling at destination.



Cold Feed System

Number of Bins	2 (1 Hopper)	
Capacity	8Tons	5.00 M3
With Included Extensions	10Tons	6.25 M3

Drum Mix

Diameter	40"	1.00 Mt
Length	20'	6.00 Mts
Drive	20HP	
Dryer Capacity	45TPH	

Burner

Type	Dual Stage, L/H Pressure	
Capacity	6MBTU	
Blower Drive	7.5HP	
Fuel Type	Dual (H/Oil & Diesel)	



Dual Fines Control System

Wet Scrubber		
Water Pump	118 LPM	25.94 GPM
Cyclone Box		
No. of Cyclones	32	
Exhaust Fan Drive	20 HP	

Asphalt Tank

Capacity	15,100 Lts	4,000 gal.
Heating System	Direct Fired	
Burner Make	Ecoflam (Italy)	
Burner Capacity	1 MBTU	
Hot Oil System	Scavenger Coils Recirc. Pump	

Fuel Tank

Capacity:	1,1134 Lts	300 Gals
-----------	------------	----------

Batcher

Capacity	1,100 Pds	500 Kgs
----------	-----------	---------





DMI 45 PORTABLE ASPHALT DRUM MIX PLANT

Dimensions

Main Unit

Length	47' 10"	14.60 Mts
Width	7' 4"	2.22 Mts
Height	11'	3.35 Mts
Weight	42,416 Lbs	19.28 Tons

Alphalt Tank

Length	24' 5"	7.46 Mts
Width	7' 3"	2.20 Mts
Height	11' 6"	3.50 Mts
Weight	12,408 Lbs	5.64 Tons

Discharge Conveyor

Length	34'	10.37 Mts
Width	22"	0.55 Mts
Batch Height	12'	3.26 Mts

Generator

Generator Required: 100 KW

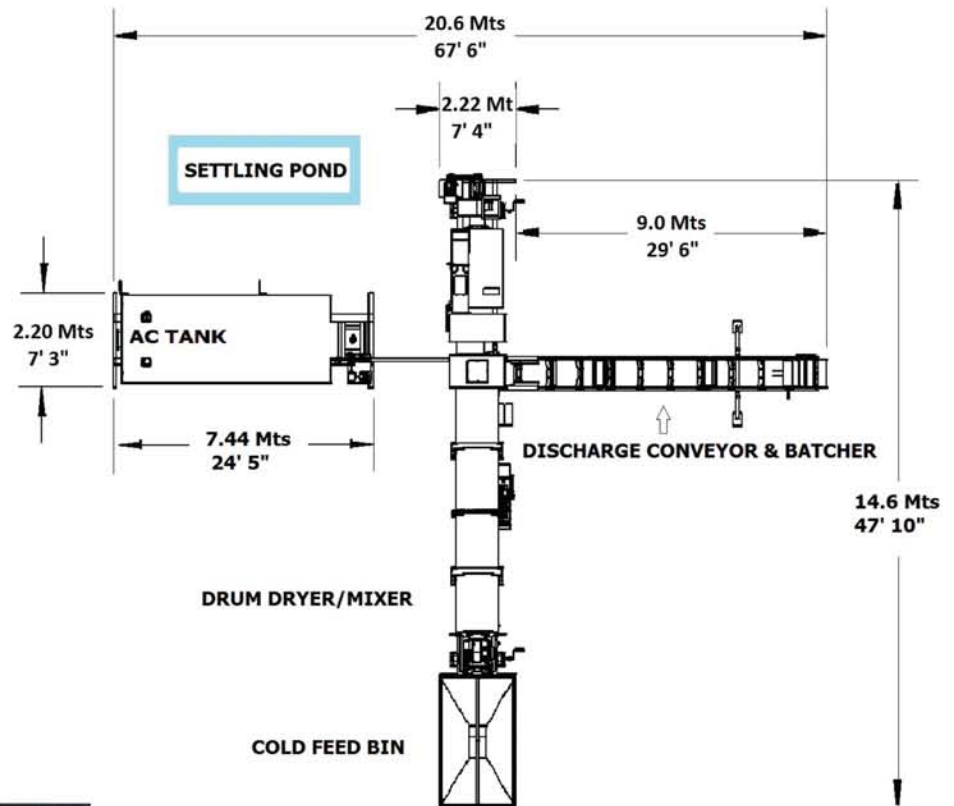

DMI 45 - OVERALL PLANT LAYOUT

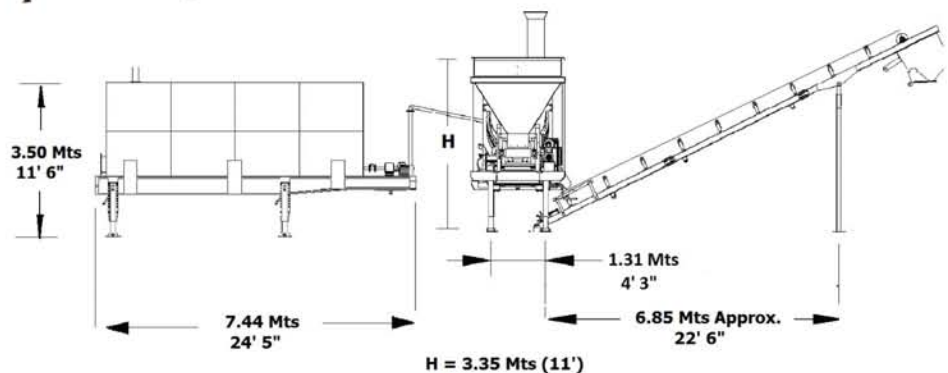

Advantages

- Pre-wired Quick Attach Connections
- Dual Fuel Burner
- Dual Dust Control System
- Detachable Control Panel
- Ships in 2 @40' Containers
- Completely Portable

www.dmi-asphalteequipment.com
sales@dmi-asphalteequipment.com